

## Solar radiation sensor ISET Sensor high-quality measurement technology for the mass market

### The new ISET Sensor

Photovoltaic plant system operators want to have simple, quick and reliable information about the function of their PV-plant.

Thermoelectric radiation sensors cannot be compared easily with a real PV-generator with respect to the "energy yield" because of their different spectral sensitiveness as well as their different reflection- and temperature characteristics.

In addition you have the relatively high acquisition cost.

In contrast to this, the radiation sensors of the lower price category do not fulfill the long-term accuracy requirements and may find no acceptance because of their "low-cost equipment", in particular in the field of buildings.

The solar cell sensor **ISET Sensor** eliminates these deficits. It fits well the physical characteristics of the solar generator. The simple and compact but nevertheless precise construction predestine it for use in the field of building measurement technology.

With the new housing design it gains the necessary acceptance in the technical services for facilities as well as in the general field of architecture.

### Technical features of the ISET Sensor

The solar radiation is converted into a proportional current by an exact defined solar cell. Via a specific shunt resistance which is coupled thermically to the compact aluminum housing, the measured voltage is determined.

The almost identical geometrical construction of the test cell, comparable with PV modules, as well as the specifically formed housing with possibilities of outside temperature link-up and high weather resistance assure reproducible results of measurement.

A Pt 1000 - temperature sensor registers the cell temperature over a two-wire data line with high measuring accuracy.

The calibration of every **ISET Sensor** is achieved with a reference element constructed in an identical fashion by an accredited test laboratory in  $W/m^2$  and is documented on a quality assurance calibrating certificate.

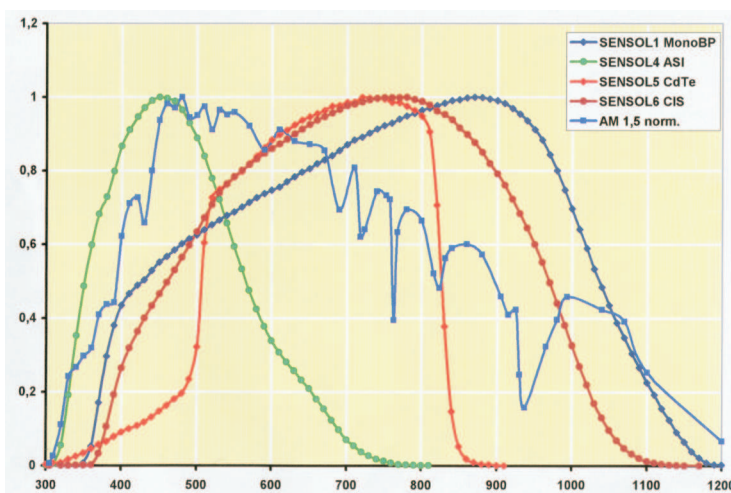

Spectral sensitivity of different **ISET Sensor** sensors under AM 1,5 (normalized).

It is clearly visible and derivable that for the energetical rating and monitoring of a PV-plant should only be used the same technology of the sensor and the PV-plant because of the different spectral sensitivity of the different technologies. Further there are the same physical characteristics regarding temperature, reflection and degradation.

With the **ISET Sensor** for each photovoltaic technology the suitable radiation sensor can be delivered.

# ISET Sensor



## Monitoring concept

Using the **ISET Sensor** in a monitoring concept the received radiation power measured on the PV generator level is compared with the output (AC) generated by the PV system.

The comparison quotient represents a functional and quality parameter for the PV-plant in the simplest way.

By the implemented evaluation logic, solar module manufacturers, traders and even electricians receive via the cumulated energy output an insight into a simplified "course of life documentation" of their products. In this way, questions about a "guaranteed" energy output are discussed more reasonably, the energy output can be provable.

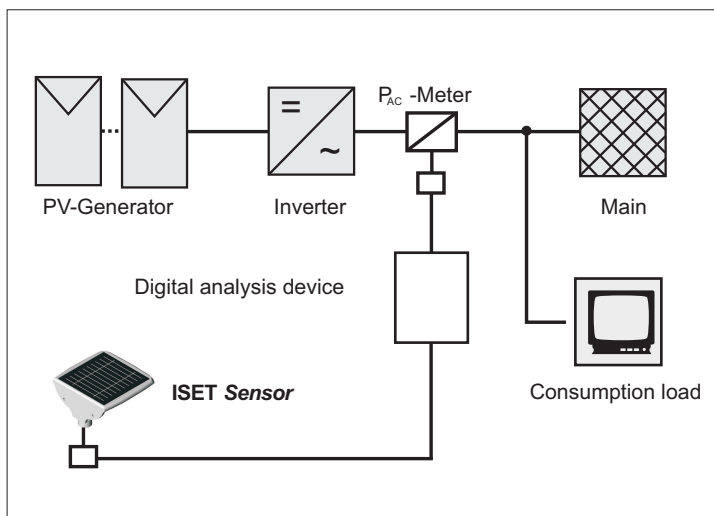

Monitoringsystem

## Technical data ISET Sensor

### Housing

- Aluminum, powder coating in facade quality, color is silvery grey \*
- Mounting with two nuts M 5 backside
- Housing pressure balance by means of a special membrane.

### Connecting cable

AWG 26, shielded, black, length 3 m, Plug connected

### Available solar cell sensors

- monocrystalline
- polycrystalline
- amorphous

Embedded under clear glass hardened thermicly or embedded like solar module

### Measuring voltage

- about 100 mV (cal.val.) / 1000 W/m<sup>2</sup>, 25°C
- Specific shunt resistance coupled thermicly to the case.

### Calibration

The calibration of every **ISET Sensor** is achieved by a reference element (quality grade A, constructed in an identical fashion) from an accredited test laboratory in W/m<sup>2</sup> by IWES/Kassel.

A calibrating printout similar to EN DIN 17025 documents the product specific parameters.

The relative measurement uncertainty is < ±4% (cryst.mat.) / < ±5% (am. mat.) The measurement uncertainty refers to a confidence level of 1-alpha =95%

### Temperature sensor

Pt 1000, laminated or bonded centrally under the cell

### Operating temperature range

-25° to + 80° C

Subject to alteration. State: 2014-06

IKS Photovoltaik GmbH  
An der Kurhessenhalle 16 b  
34134 Kassel / Germany  
Phone +49 (0) 561 / 9538050  
Fax +49 (0) 561 / 9538051  
Www.iks-photovoltaik.de  
info@iks-photovoltaik.de



Training systems  
Measurement engineering  
Special developments

Reseller